

GSZ-10S Shotcrete Machine (Dry and Wet)



◆ Product Description

GSZ-10S Shotcrete machine is a multifunctional rotor type machine for wet and dry spraying and conveying. The materials which can be sprayed and conveyed are concrete, mortar, refractory, sand, pea gravel and crushed stone.

Compared with traditional shotcrete machines, GSZ-10S has the advantages of being lighter and more compact. By changing the rotor of different sizes and adjusting the motor speed, the theoretical displacement range is 0.7~10m³/h, which can better meet the needs of customers. In addition, GSZ-10S is equipped with rubber sealing plate lubrication system, which can effectively reduce the wear of rubber plate, longer service life and better sealing effect.

◆ Advantages and Benefits

- 1.Theoretical output from 0.7 up to 10 m³/h.
2. Easily overcome obstacles of long or high conveying distances (dry mix).
3. Less dust development.
4. Reduced rebound.
5. For concrete repair, slope stabilization, excavation support or in mining.
6. Light and compact machine design.
- 7.Stepless adjustment of conveying capacity.
- 8.Remote control.

◆ **Standard Configuration**

1. Automatic lubrication system
2. Frequency convertor
3. Vibrating hopper

◆ **Rubber and steel sealing plates**

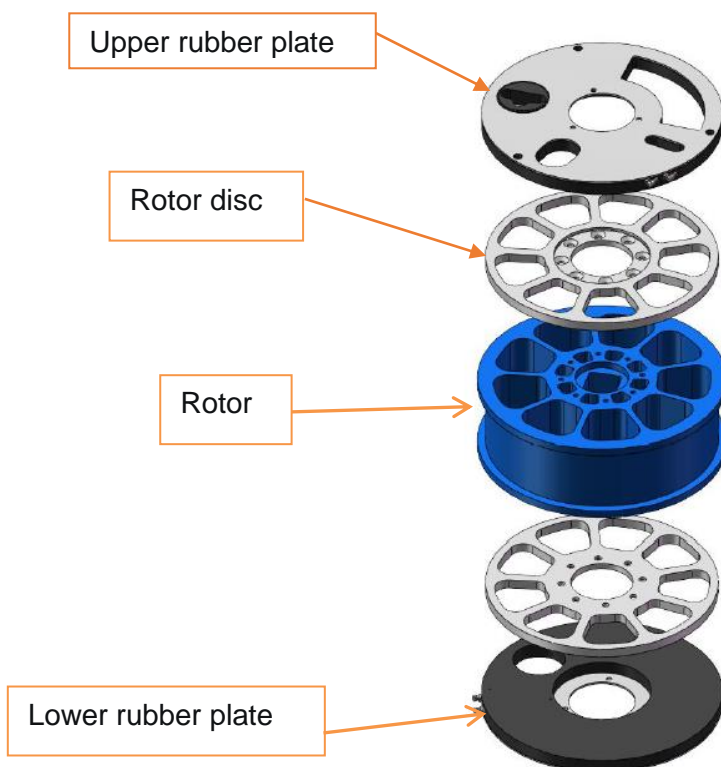

◆ Dimension Figure

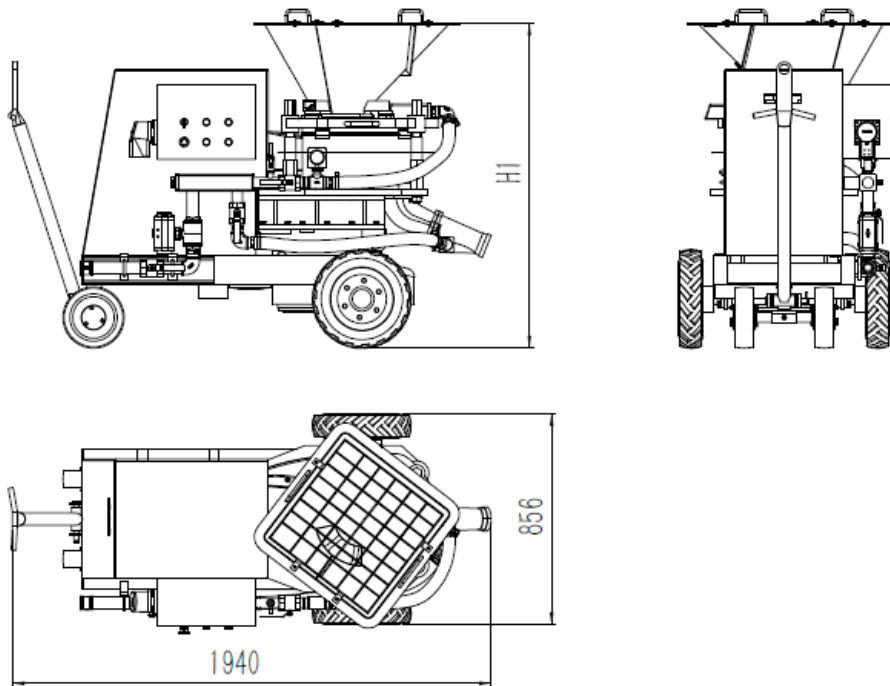

Rotor	H1
13L	1320mm
10L	1285mm
7L	1250mm
2,7L	1200mm

weight: ~1000Kg

◆ Technical Data

Name	Data			
Machine Type	Rotary machine GSZ-10S			
Process	Thin-stream			
Motor power	7.5 kw			
Power supply	3X380-480V. 50/60Hz			
Rotor size in liters	2.7	7	10	13
Theoretical output in m ³ /h ①	0.7-2.0	2.0-5.3	2.9-7.6	3.7-10
Recommended hose sizes	D38	D51	D51	D64
Grain sizes in mm	12	16	16	20
Max.conveying distance in m horizontal/vertical	Dry:		300/100	
	Wet:		40/15	
Dimensions in mm	Length		1940	
	Height		H1	
	Width		856	
Weight in kg	1000 Kg			
① Based on a theoretical filling level of 100%. Prior to use or processing, always consult the current product data sheet of the products used				
We could also customize according to your demands.				

◆ Detail part

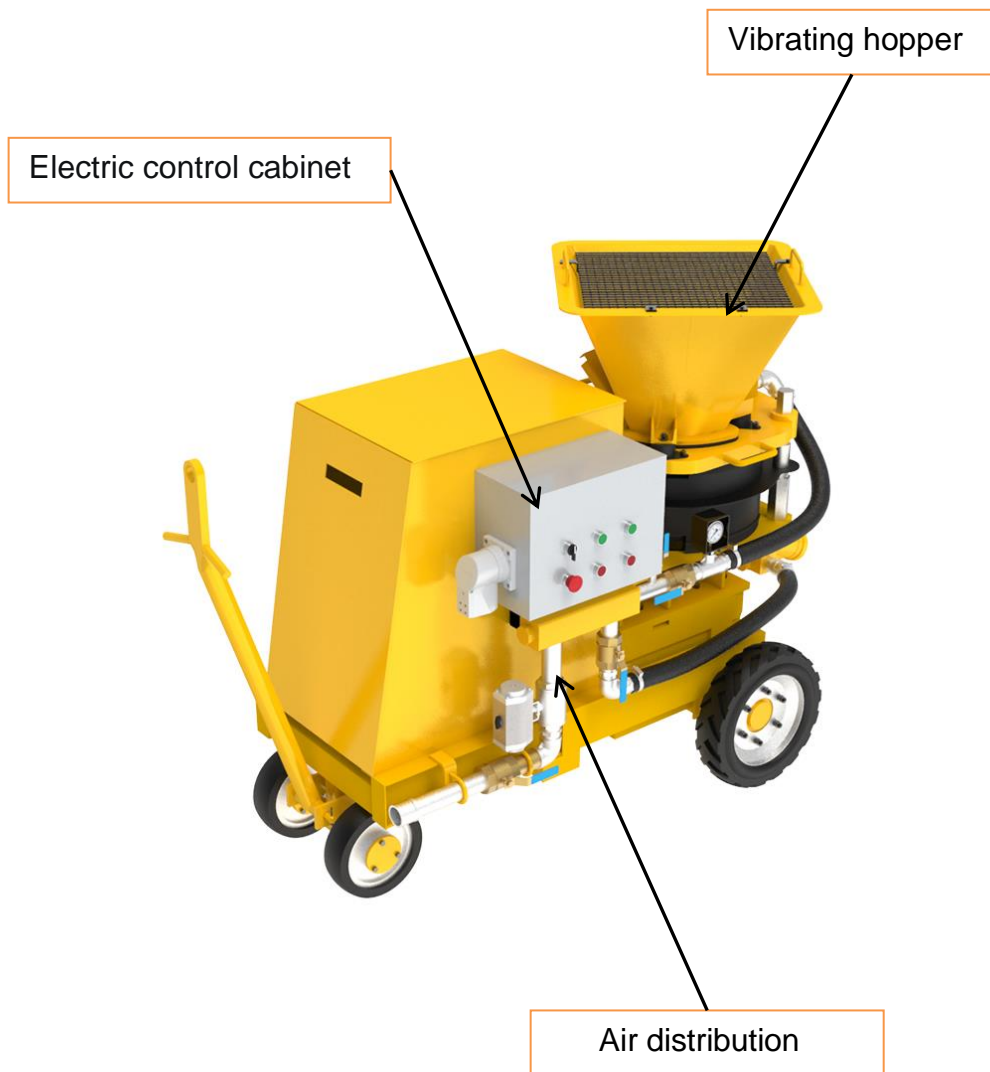

GSZ-10S Shotcrete Machine(Dry and Wet)

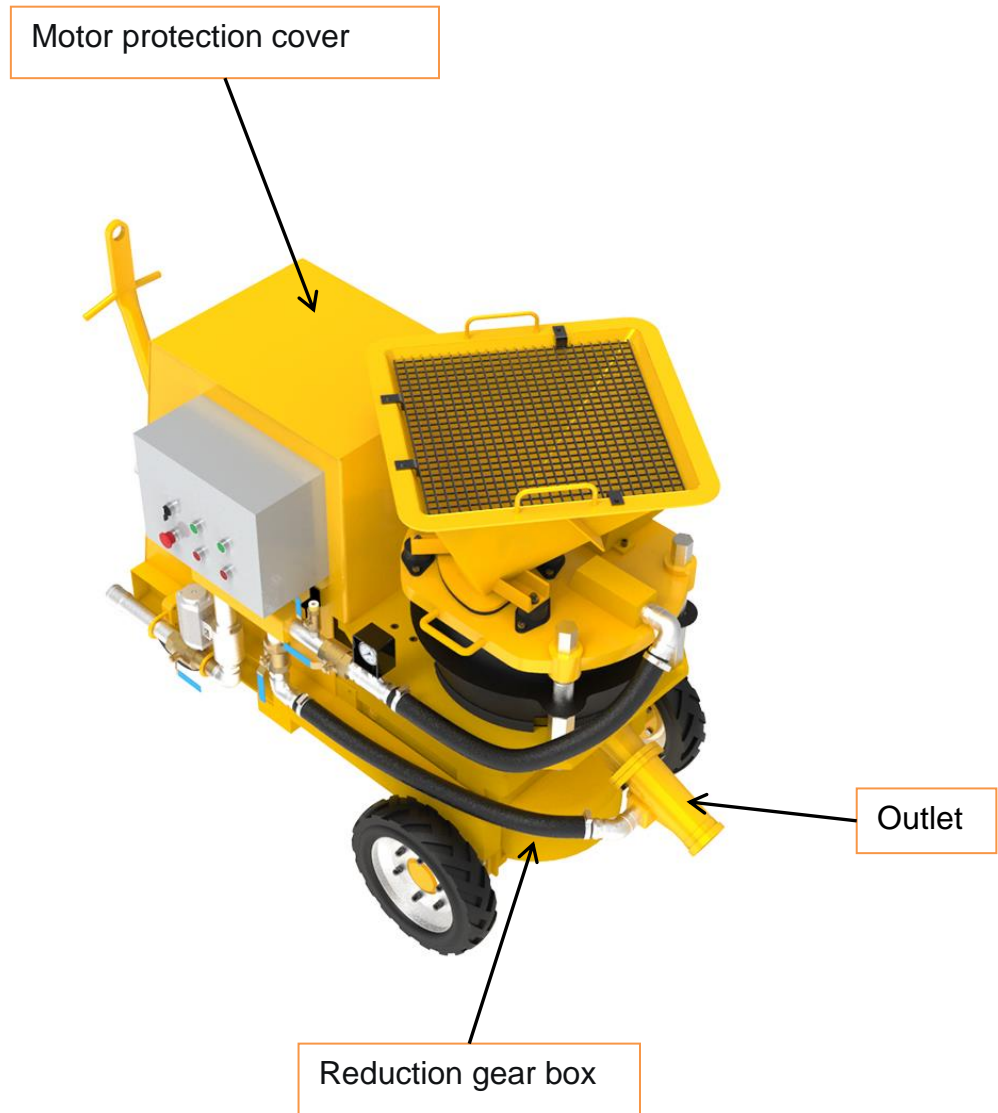

GSZ-10S Shotcrete Machine(Dry and Wet)

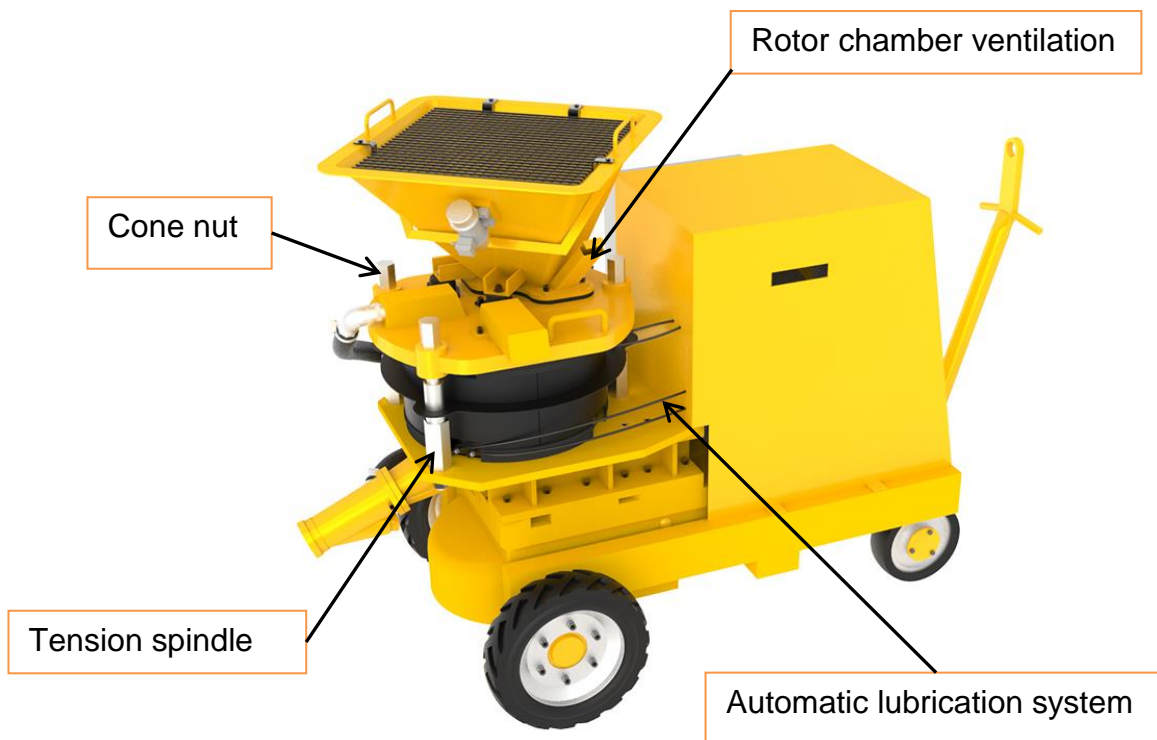

Gaode Equipment Co., Ltd.

Add: No.9, Building 14, Yard No.4, Fengqing Road, Jinshui District,
Zhengzhou, Henan China

Web: <https://www.gaodetec.com>

Email: info@gaodetec.com

Tel: +86-371-55951660